

**SOVA LED DOWNLIGHT**

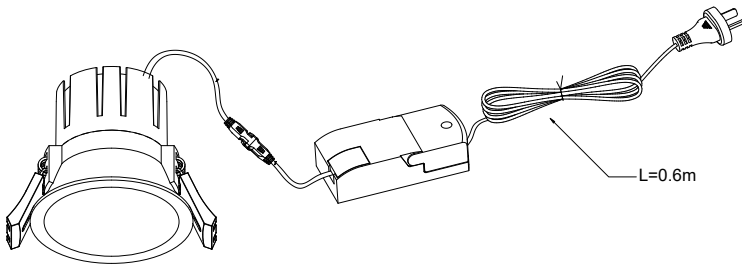

Specification			
Item Name	SOVA DL70		SOVA DL93
Watt	6W		6-10W
Input	220-240V 50Hz		
Lumen	630*		1050*
CCT	3000K		
CRI	90+		
Dimension	D: 70mm H: 63mm	D: 93mm H: 87mm	
Surge Protection	Yes		
Cutout size	65mm		85mm



**FITTING MUST BE INSTALLED BY A QUALIFIED ELECTRICIAN**

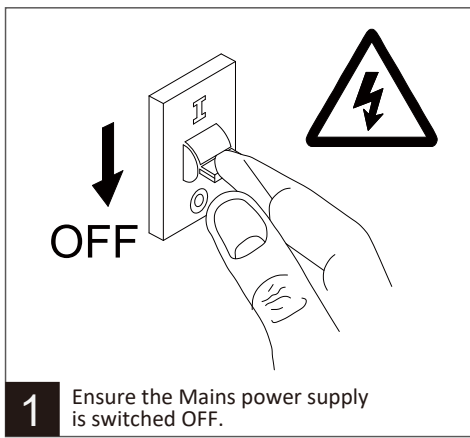

**1** Ensure the Mains power supply is switched OFF.

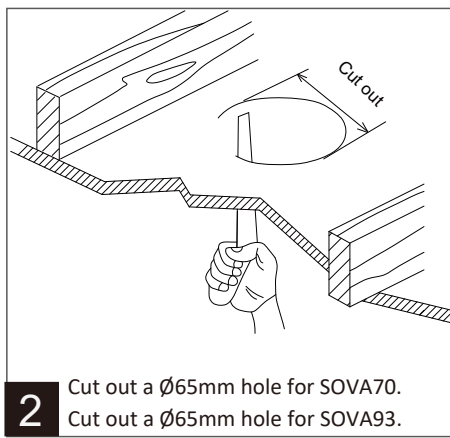

**2** Cut out a Ø65mm hole for SOVA70. Cut out a Ø65mm hole for SOVA93.

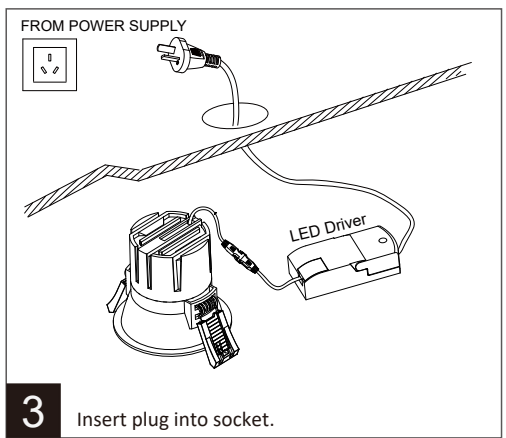

**3** Insert plug into socket.

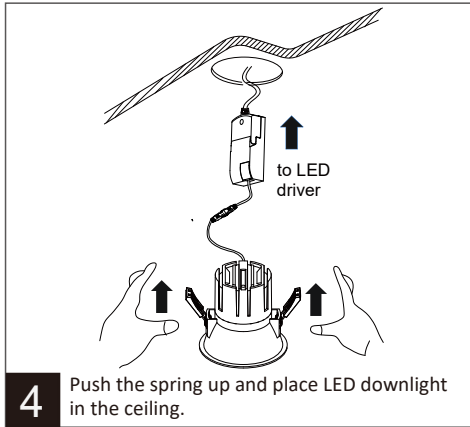

**4** Push the spring up and place LED downlight in the ceiling.

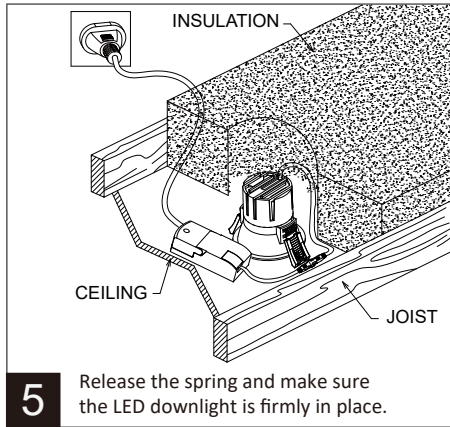

**5** Release the spring and make sure the LED downlight is firmly in place.

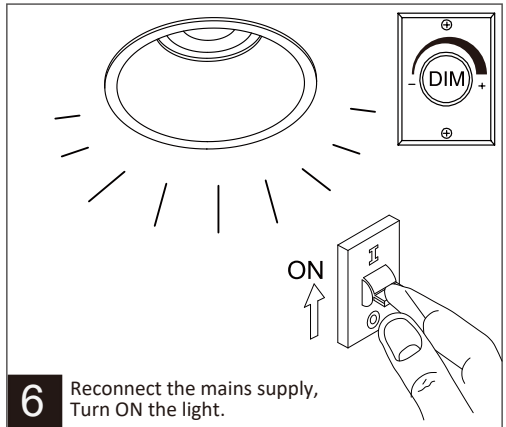

**6** Reconnect the mains supply, Turn ON the light.

**IMPORTANT**

Insulation class IC-4 covered. Must be of a type that can maintain its dimension and structural rigidity when exposed to maximum surface temperatures of this class of luminaire, being 90°C, and tested in accordance with AS/NZS 60695.11.5

Insulation type as tested is glass wool (pink wool).

**LOOSE FILL INSULATION IS NOT PERMITTED**

**WARNING:** Risk of overheating or fire if the clearance distance are compromised.

**WARNING**

1. Installation, repair or inspection must be conducted by qualified electricians
2. Care must be taken to ensure electrical wiring and other hidden utilities are not damaged when ceiling is cut.
3. Do not install in a position where the unit will be accessible to children or infirm persons.
4. Do not perform modification to the unit.
5. If the supply cord is damaged it should be replaced by the qualified electricians to avoid a hazard.

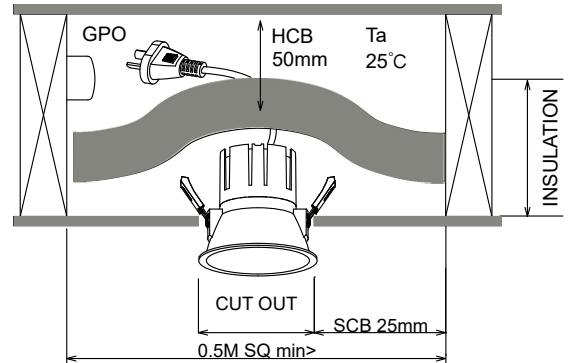

TELBIX LED FIXTURES are covered by \* **FIVE YEAR REPLACEMENT WARRANTY** (domestic installations).  
**THREE** year replacement warranty (commercial installation) as stated on the terms and conditions herein.

Please also note warranty requirements will need the following details:

- model number
- the production number (PO#)
- date of purchase
- place of purchase
- copy receipt of purchase
- copy of Electrical Contractors compliance certificate

## WARRANTY PERIOD

The warranty only applies if the products have been installed in accordance with the installation instructions included with the product.  
The \***FIVE YEAR REPLACEMENT WARRANTY** applies to domestic use only, commencing from date of purchase.  
Copies of receipts of purchase and Electrical Contractors compliance certificate are required.

## WARRANTY CONDITIONS ON TELBIX PRODUCTS

1. TELBIX warrants that the LED products you have purchased are free from manufacturing defects in materials and workmanship when dispatch from our warehouse. The receipt of purchase shall be provided as proof of the date of purchase and the warranty period commences as of that date.
2. The warranty also requires that electrical installations must be completed in accordance with AS/NZS3000 and to this affect a copy of the Electrical Compliance Certificate for the said products must be provided.
3. During the warranty period, TELBIX must be notified in writing of any claim prior to any return or rectification of products.
4. Proof of purchase will be required in the event of any discrepancy.
5. The warranty automatically becomes void if the product has been physically damaged or rendered defective-
  - (a) as a result of an accident, misuse, fire, lighting, malicious damage, water damage, abuse or other circumstances beyond the control of TELBIX;
  - (b) by the use of parts or peripherals not authorized by TELBIX;
  - (c) by use in an improper operating environment;
  - (d) by modification of the product;
  - (e) by the serial number or product code sticker being removed or defaced;
  - (f) as a result of a service by anyone other than TELBIX authorized service agent;
  - (g) by use on an incorrect voltage, power surges and dips.
6. TELBIX authorized service agents (if required) will be chargeable at current applicable hourly rates to the customer if-
  - (a) the technician finds the problem is user related;
  - (b) caused by change in normal settings of the original product;
  - (c) determined to be causes not covered by this warranty and/or fallen within the scope as prescribed in item 5.
7. The customer must ensure that they are available if a service representative arrives to carry out warranty inspection. Any additional visits made due to the customer's unavailability will be chargeable to the customer.
8. This warranty applies to the original purchaser only and is not transferable.
9. This warranty does not apply if goods were purchased from a clearance centre, auction house or goods were sold as samples or seconds.

**If the external flex cord is damaged, it need to be replace by Manufacturer or qualified personnel to avoid hazard.**

**WARNING: RISK OF OVERHEATING OR FIRE IF THE CLEARANCE DISTANCE ARE COMPROMISED**

## LIMITATION OF LIABILITY

TELBIX warrants that the product you have purchased is free from manufacturing defects in materials and workmanship when dispatched from our warehouse. In Australia: Provisions of the Competition and Consumer Act 2010 (Commonwealth) as amended and other State legislation may imply warranties or conditions or impose obligations upon TELBIX which cannot, in whole or in part, be excluded, restricted or modified. To the extent permitted by law, TELBIX's liability (if any) arising out of or in relation to the products supplied by TELBIX shall be limited, as its option, to: in the case of products, the replacement or repair of the products or the supply of equivalent products, or the payment of the cost of replacing the products or having the products repaired or of acquiring equivalent products.