

SOVA LED CLOSE TO CEILING

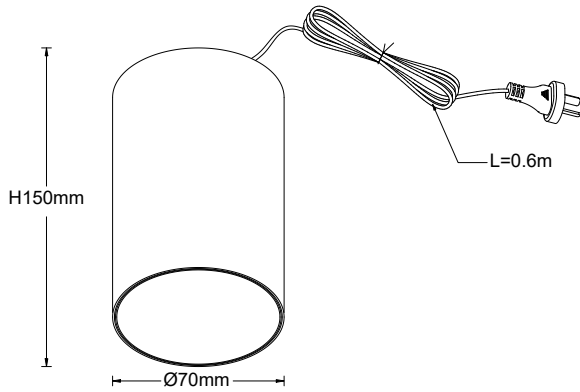

Specification	
Item Name	SOVA CTC70
Watt	10W
Input	220-240V 50Hz
Lumen	1050*
CCT	3000K
CRI	90+
Dimmable	Yes
Surge Protection	Yes
Dimension	D: 70mm H: 150mm



FITTING MUST BE INSTALLED BY A QUALIFIED ELECTRICIAN

1 Ensure the Mains power supply is switched OFF.

2 Cut out a hole for power cable.

3 Installing the panels on the ceiling

4 Push the spring up and place LED downlight in the ceiling.

5

6 Reconnect the mains supply, Turn on the light.

WARNING

1. Installation, repair or inspection must be conducted by qualified electricians
2. Care must be taken to ensure electrical wiring and other hidden utilities are not damaged when ceiling is cut.
3. Do not install in a position where the unit will be accessible to children or infirm persons.
4. Do not perform modification to the unit.
5. If the supply cord is damaged it should be replaced by the qualified electricians to avoid a hazard.

TELBIX LED FIXTURES are covered by * **FIVE YEAR REPLACEMENT WARRANTY** (domestic installations).
THREE year replacement warranty (commercial installation) as stated on the terms and conditions herein.

Please also note warranty requirements will need the following details:

- model number
- the production number (PO#)
- date of purchase
- place of purchase
- copy receipt of purchase
- copy of Electrical Contractors compliance certificate

WARRANTY PERIOD

The warranty only applies if the products have been installed in accordance with the installation instructions included with the product.
The ***FIVE YEAR REPLACEMENT WARRANTY** applies to domestic use only, commencing from date of purchase.
Copies of receipts of purchase and Electrical Contractors compliance certificate are required.

WARRANTY CONDITIONS ON TELBIX PRODUCTS

1. TELBIX warrants that the LED products you have purchased are free from manufacturing defects in materials and workmanship when dispatch from our warehouse. The receipt of purchase shall be provided as proof of the date of purchase and the warranty period commences as of that date.
2. The warranty also requires that electrical installations must be completed in accordance with AS/NZS3000 and to this affect a copy of the Electrical Compliance Certificate for the said products must be provided.
3. During the warranty period, TELBIX must be notified in writing of any claim prior to any return or rectification of products.
4. Proof of purchase will be required in the event of any discrepancy.
5. The warranty automatically becomes void if the product has been physically damaged or rendered defective-
 - (a) as a result of an accident, misuse, fire, lighting, malicious damage, water damage, abuse or other circumstances beyond the control of TELBIX;
 - (b) by the use of parts or peripherals not authorized by TELBIX;
 - (c) by use in an improper operating environment;
 - (d) by modification of the product;
 - (e) by the serial number or product code sticker being removed or defaced;
 - (f) as a result of a service by anyone other than TELBIX authorized service agent;
 - (g) by use on an incorrect voltage, power surges and dips.
6. TELBIX authorized service agents (if required) will be chargeable at current applicable hourly rates to the customer if-
 - (a) the technician finds the problem is user related;
 - (b) caused by change in normal settings of the original product;
 - (c) determined to be causes not covered by this warranty and/or fallen within the scope as prescribed in item 5.
7. The customer must ensure that they are available if a service representative arrives to carry out warranty inspection. Any additional visits made due to the customer's unavailability will be chargeable to the customer.
8. This warranty applies to the original purchaser only and is not transferable.
9. This warranty does not apply if goods were purchased from a clearance centre, auction house or goods were sold as samples or seconds.

If the external flex cord is damaged, it need to be replace by Manufacturer or qualified personnel to avoid hazard.

WARNING: RISK OF OVERHEATING OR FIRE IF THE CLEARANCE DISTANCE ARE COMPROMISED

LIMITATION OF LIABILITY

TELBIX warrants that the product you have purchased is free from manufacturing defects in materials and workmanship when dispatched from our warehouse. In Australia: Provisions of the Competition and Consumer Act 2010 (Commonwealth) as amended and other State legislation may imply warranties or conditions or impose obligations upon TELBIX which cannot, in whole or in part, be excluded, restricted or modified. To the extent permitted by law, TELBIX's liability (if any) arising out of or in relation to the products supplied by TELBIX shall be limited, as its option, to: in the case of products, the replacement or repair of the products or the supply of equivalent products, or the payment of the cost of replacing the products or having the products repaired or of acquiring equivalent products.