

## LP-1919S-SM-1M

### LED Profile SM 20 x 20mm P/M C/W SQR DIF

#### Description

Introducing the LP-1919S-SM LED mounting profile system. The LP-1919S-SM is specifically designed for the Domus range of LED strip lighting. This aluminium mounting profile system incorporated extruded profile complete with a square opal colour PMMA diffuser. The key features of the LP-1919S-SM is the ability to not only conceal the LED strip lighting but also keep the strip lighting linear. Also, the LP-1919S-SM keeps LEDs free from foreign objects and vapours which may damage the LEDs. The finishing of this product is a perfect complement to any area where discrete lighting is required. Applications include lounge rooms, dining areas, bathrooms, storage areas, shelving or any other architectural application.



#### Specification Features

Installation:	Surface, wall or suspended mounted
Material:	Extruded aluminium 6063
Finish:	Natural clear anodised
Diffuser:	Square (PMMA) Opal colour
Length (mm):	2500mm continuous*
Size (mm):	(W) 19.8mm (H) 19.6mm
Accessories (each):	End caps (anodised), wire suspensions and mounting clips**
Special:	Custom powder coated colour upon request***
Driver Installation:	Remote driver required (not included)

\* Profile sold per meter. Can be cut to suit any length.

\*\* Accessories to be ordered separately.

\*\*\* Special powder coat finishes upon request. Surcharges apply.

#### PLEX Compatible Strip

PLEX-COB-5-IP54	PLEX-RGBTW-IP67
PLEX-COB-10-IP54	PLEX-RGB-IP54
PLEX-COB-15-IP54	PLEX-RGB-IP67
PLEX-COB-20-IP54	PLEX-COB-TW-IP54
PLEX-COB-5-IP67	PLEX-COB-TW-IP67
PLEX-COB-10-IP67	PLEX-MICRO
PLEX-COB-15-IP67	PLEX-ULTRA-IP54
PLEX-COB-20-IP67	PLEX-ULTRA-IP67
PLEX-VIVID-IP54	PLEX-SMD-5-IP66
PLEX-VIVID-IP67	PLEX-SMD-9-IP54
PLEX-RGBTW-IP54	PLEX-SMD-9-IP67

#### Diagrams / Additional

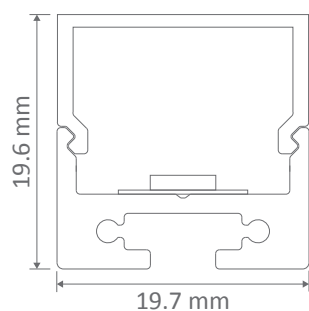

Item No.	Variant			Details
	Alu	Blk	Wht	
LP-1919S-SM-1M	22010	22068	22069	Sold per 1 metre
SUSP-KIT		22041		2 metres standard height, sold individually



Suspension Kit