

ITEM NO.: KENRA EX.P

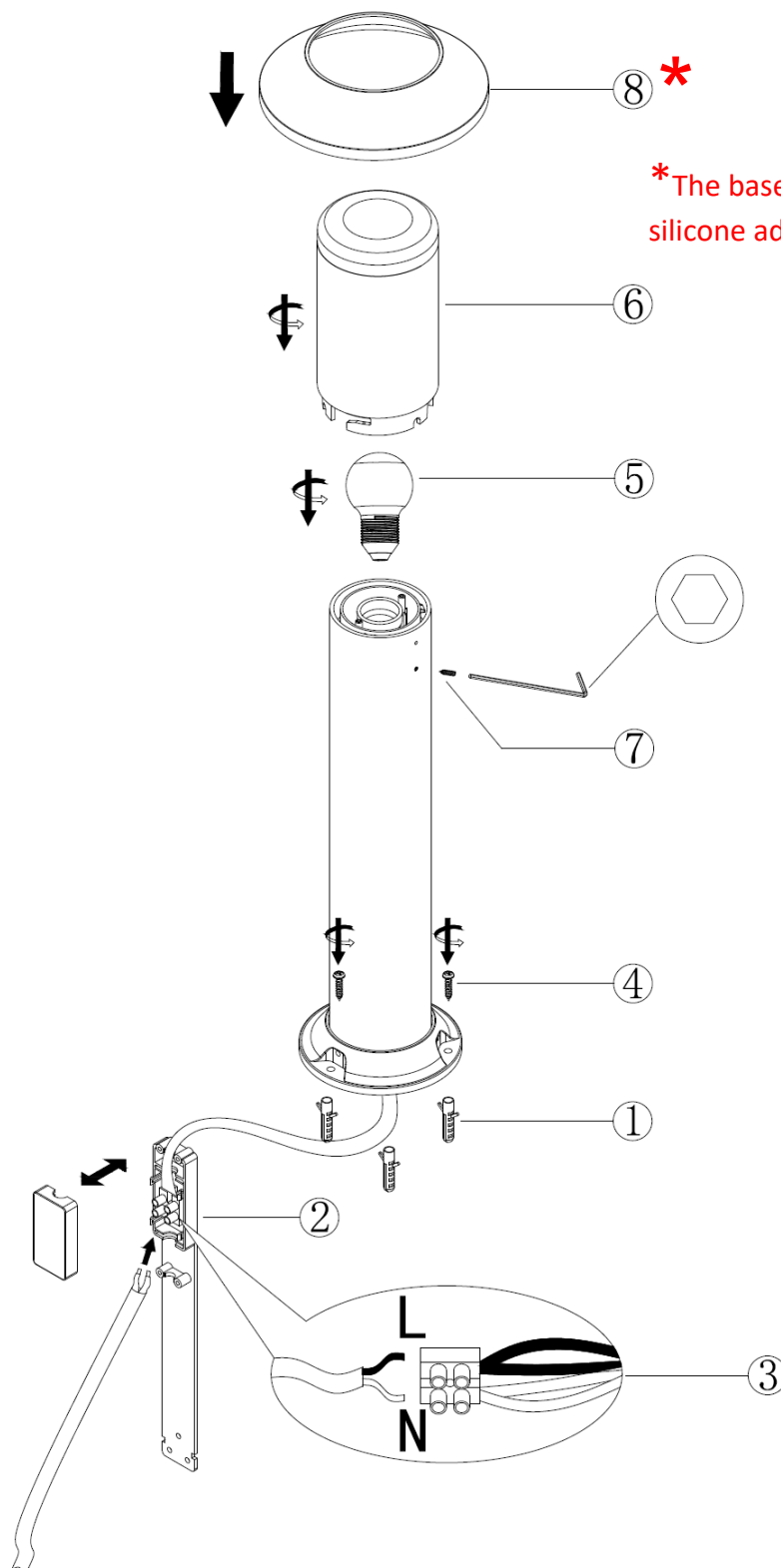

*The base cover cap (8) can be secured using silicone adhesive.

IMPORTANT
Must be installed by a qualified electrical contractor.
Install in accordance with AS/NZS3000

240V ~ 50Hz E27 Max.25Wx1

NOTE: GLOBE NOT INCLUDED

Telbix.

IP44

