

ITEM NO.: BREVAN WB2

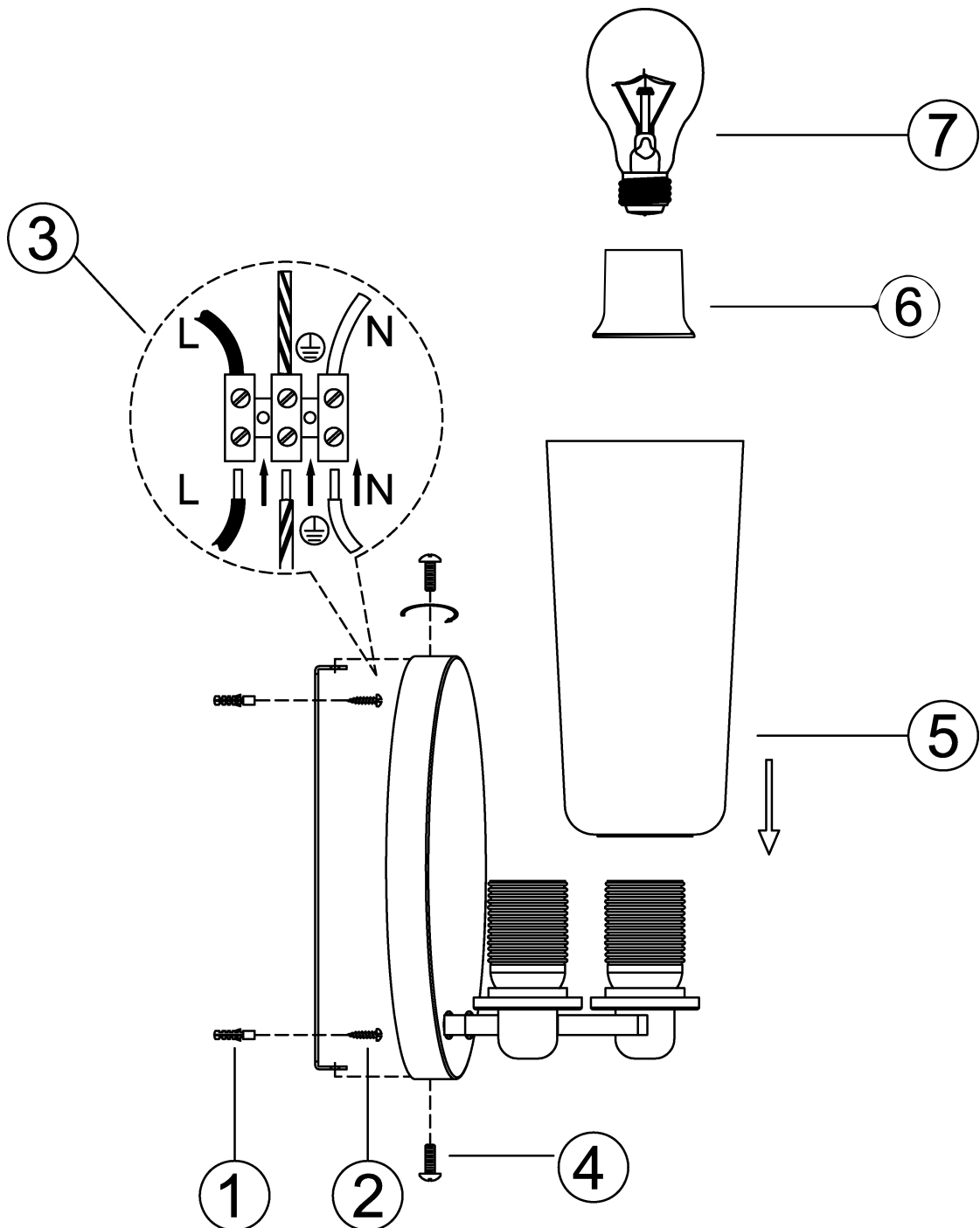

Disclaimer:
/ / Tools not included
Shade ring attached on lamp holder
Globe(s) not included



IP20

240V - 50Hz E27 Max.25Wx2

Telbix.

NOTE: GLOBE NOT INCLUDED

IMPORTANT
Must be installed by a qualified electrical contractor.
Install in accordance with AS/NSZ3000.